

The Crescendo 15B and 18B are intended for high level, high power low frequency reproduction in ported enclosures. They feature vented die cast chassis and composite glass fibre and black anodized aluminium coil formers, yielding extremely low thermal compression. Both employ high rigidity cone membranes in order to offer freedom from breakup and associated distortion at

extremely high sound pressure levels. Extended levels of linear excursion are possible due to long throw motor systems coupled with large flexure suspensions. The 15B is suitable for use in 70 to 200 litre ported enclosures and features a 3 inch voice coil, 400 watt power handling and 96 dB sensitivity. It is capable of delivering bass down to 39 Hz (-6 dB) in a 125 litre cabinet.

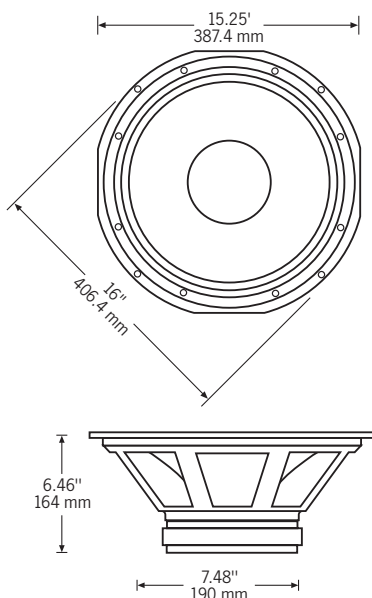

Mounting information

Overall Diameter	16 inch/406.4 mm
Width Across Flats	15.25 inch/387.4 mm
Flange Thickness	0.305 inch/7.8 mm
Baffle Hole Diameter, Front Mount	13.85 inch/352 mm
Baffle Hole Diameter, Rear Mount	14.00 inch/355 mm
Gasket Supplied	Front & rear
Fixing Holes	4 x 0.28 inch diam on 15.5 PCD, 8 x 0.28 diam on 14.56 PCD 4 x 7.1 mm diam on 393.7 PCD, 8 x 7.1 diam on 370 PCD
Depth	6.46 inch/164 mm
Weight	18.74 lb/8.5 kg
Recommended Enclosure Volume	2.47-7.06 cu ft/70-200 litres
Volume Displaced by Driver	0.177 cu ft/5 litres
Shipping Weight	21.8 lb/9.9 kg
Packing Carton Dimensions	415 x 415 x 250 mm

Frequency response data

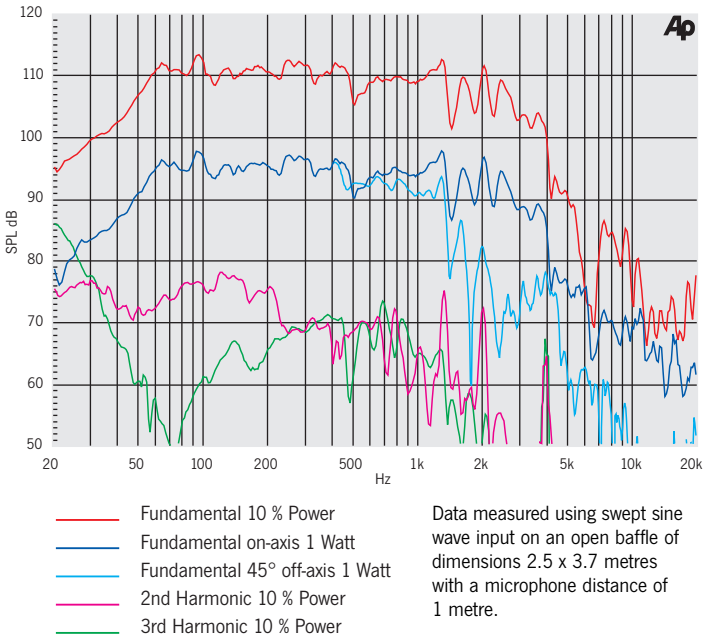

Impedance

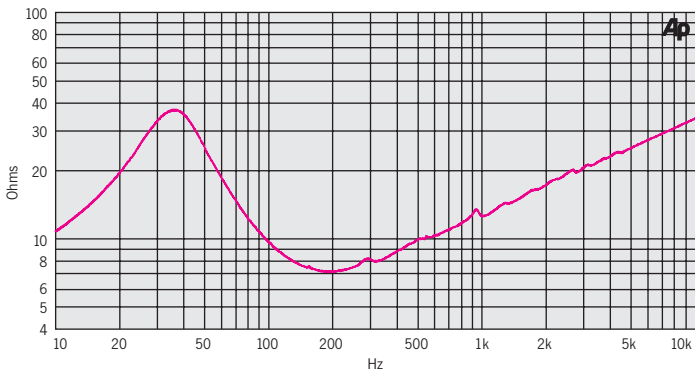

Computer predicted bass response

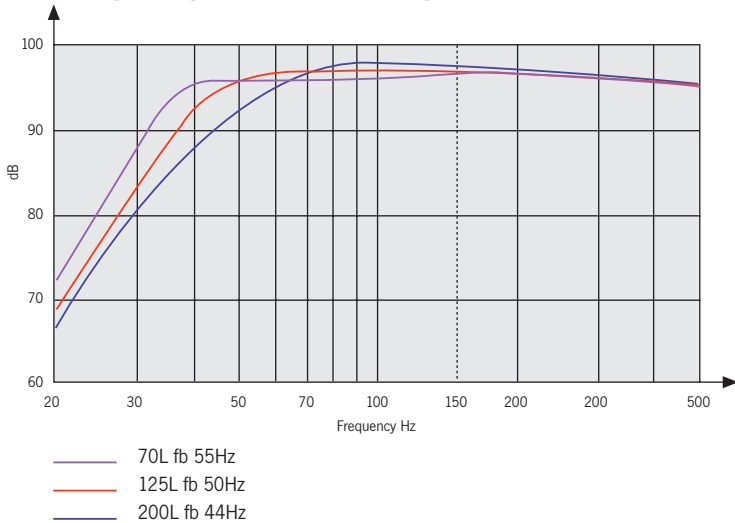

Electro mechanical specifications

Nominal Chassis Diameter	15 inch/381 mm
Impedance	8 Ω
Power Handling	400 (A.E.S.) ¹
Maximum Output Continuous/Peak	118/124 dB
Power Compression at Rated Power	4.5 dB
Usable Frequency Range (-6 dB)	33 Hz-2 kHz
Average Sensitivity (in above range) 1W/1m	96 dB
Resonance	34 Hz
Moving Mass inc. Air Load	111 grams
BL Product (Newtons/amp)	22.4
Minimum Impedance (Zmin)	7 Ω
Effective Piston Diameter	12.76 inch/324 mm
Flux Density	1.1 Tesla
Magnetic Gap Depth	0.39 inch/10 mm
Coil Winding Height	0.76 inch/19.4 mm
Voice Coil Length	82 feet/25 m
Magnet Weight	93 oz/2.65 kg
Maximum Cone Displacement	0.55 inch/14 mm
Peak Displacement Volume of Cone, Vd	0.770 litres
Voice Coil Diameter	†3.0 inch/77 mm

Construction materials

Coil Former	Fibreglass and Black Anodised Aluminium
Voice Coil Material	Copper
Magnet	Ferrite
Chassis	Die Cast Aluminium
Cone	Curvilinear Paper
Surround/Edge Termination	Polyvinyl Damped Double Half Roll Linen
Dust Dome	Solid Paper
Connectors	Push Button Spring Terminals
Polarity	Positive voltage at red terminal causes forward motion of cone

Thiele-Small parameters

Resonant Frequency fs	34 Hz
D.C Resistance Re	5.6 Ω
Qts	0.238
Qes	0.265
Qms	2.29
Mms (grams)	111
Cms (microns per Newton)	197
BL Product	22.4 Tesla metres
Vas	188 litres
Reference Efficiency ηo	2.69 %
Piston Area Sd	0.082 m ²
Xmax	4.7 mm

¹ A.E.S. power handling test. Pink noise bandpass filtered at 12 dB per octave with cutoff frequencies of 30 Hz and 300 Hz. Driver mounted in free air, test signal applied at rated power for two hours.